

3 616 C08 A71

Stand } 07-02-14 Fig./Abb. 1  
Issue }

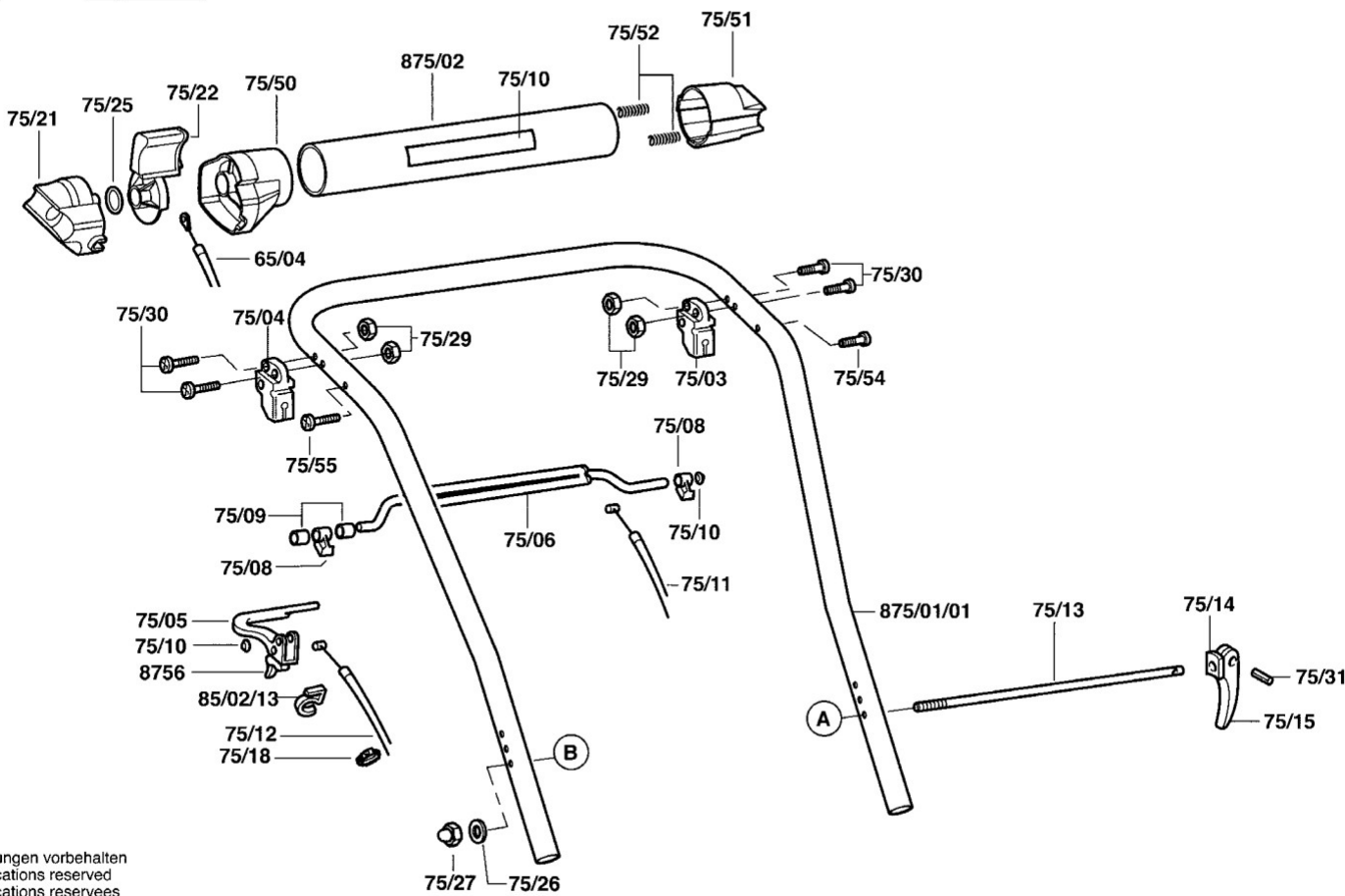

Änderungen vorbehalten  
Modifications reserved  
Modifications reserves  
Salvo modificaciones



Steve Hancke  
 Allett  
 Allett Mowers  
 Turfmech Machinery Ltd  
 Stafford  
 ST18 0PJ  
 United Kingdom

Date: 24/07/2013  
 Tel: 01889 272093  
 Fax:  
 Email: steve.hancke@allett.co.uk

Service Bill of Materials: 3616C08A711

Ref	Part #	Qty	Description	Price	RP	RD
65/04	F016A75856	1	Control Cable			
75/03	F016L36720	1	Spare Part L/H L/H			
75/04	F016L36721	1	Spare Part R/H R/H			
75/05	F016103833	1	Lever			
75/06	F016L36714	1	Control Lever			
75/08	F016L36717	2	Support			
75/09	F016L36719	3	Bushing			
75/10	F016T48990	2	Cover BLACK Ø8MM			
75/11	F016A58035	1	Cable Rear Roller			
75/12	F016A58040	1	Adjusting Part			
75/12	F016A58036	1	Clutch Cable			
75/13	F016A58203	1	Locking Pin			
75/14	F016T48856	1	Lever			
75/15	F016T48384	1	Lever			
75/18	F016W26070	3	Cable Strap			
75/21	F016A75800	1	Bracket			
75/22	F016L66176	1	Control Lever			
75/25	F016L59927	1	Nut M 4 M 4			
75/26	F016L22700	1	Spring Washer M6 M6			
75/27	F016L22701	1	Special Nut			
75/29	F016L36836	4	Nut M5 M5			
75/30	F016A75751	4	Screw M 5x32 M 5x32			
75/31	F016T56145	1	Straight Pin			
75/50	F016A75816	1	Adapter			
75/51	F016A75817	1	Adapter			
75/52	F016T49226	2	Compression Spring			
75/54	F016A75820	1	Screw			
75/55	F016A75798	1	Screw			

Steve Hancke, Steve Hancke, Allett, Allett Mowers, Turfmech Machinery Ltd, Stafford, ST18 0PJ, United Kingdom, .

3 616 C08 A71

Stand } 07-02-12 Fig./Abb. 2  
Issue }

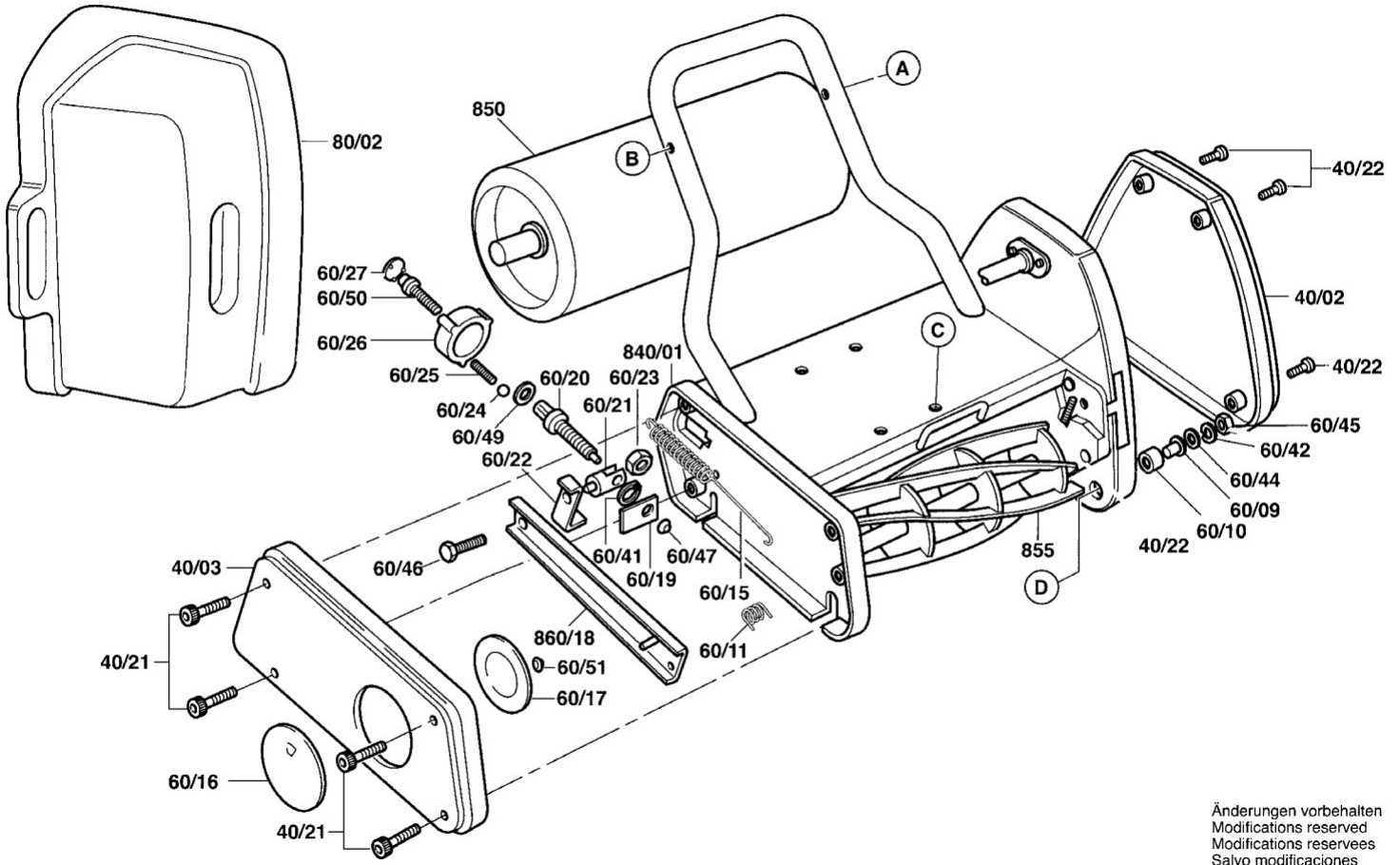

Änderungen vorbehalten  
Modifications reserved  
Modificaciones reservadas

3616C08A712 . 24/07/2013



Steve Hancke  
 Allett  
 Allett Mowers  
 Turfmech Machinery Ltd  
 Stafford  
 ST18 0PJ  
 United Kingdom

Date: 24/07/2013  
 Tel: 01889 272093  
 Fax:  
 Email: steve.hancke@allett.co.uk

## Service Bill of Materials: 3616C08A712

Ref	Part #	Qty	Description	Price	RP	RD
40/02	F016A75398	1	Protection cover LH LH			
40/03	F016A75089	1	Side Cover RH RH			
40/21	F016A58228	4	Screw M6 M6			
40/22	F016A58229	6	Screw M6 M6			
60/09	F016A57748	1	Pivot L/H L/H			
60/10	F016A57676	1	Cap			
60/11	F016A57820	1	Spring			
60/15	F016A57995	1	Spring			
60/16	F016A57576	1	Cover			
60/17	F016A57577	1	Washer			
60/19	F016A75521	1	Retaining Plate			
60/20	F016A58231	1	Spindle			
60/21	F016A58233	1	Nut			
60/22	F016A75786	1	Guide			
60/23	F016A58232	1	Nut			
60/24	F016T48358	1	Ball Bearing			
60/25	F016T48420	1	Compression Spring			
60/26	F016A58730	1	Knob			
60/27	F016T48421	1	Sealing cap			
60/41	F016L32612	1	Retaining clip			
60/42	F016L35307	3	Spring Washer 5/16 SW SE 5/16 SW SE			
60/44	F016L35411	4	Plain Washer 8,5 MM 8,5 MM			
60/45	F016L35457	3	Nut M8 M8			
60/46	F016T46338	1	Trunnion			
60/47	F016T46684	1	Washer			
60/49	F016T48359	1	Washer			
60/50	F016T48457	1	Screw M 6 M 6			
60/51	F016T48549	1	Set ring			
80/02	F016A58176	1	Catcher Container			
840/01	F016103202	1	Housing			
850	F016103216	1	Spare Part			
855	QCC176-EX	1	CARTRIDGE			
860/18	F016103796	1	Linkage			

Steve Hancke, Steve Hancke, Allett, Allett Mowers, Turfmech Machinery Ltd, Stafford, ST18 0PJ, United Kingdom, .

3 616 C08 A71

Stand } 07-02-14 **Fig./Abb. 3**

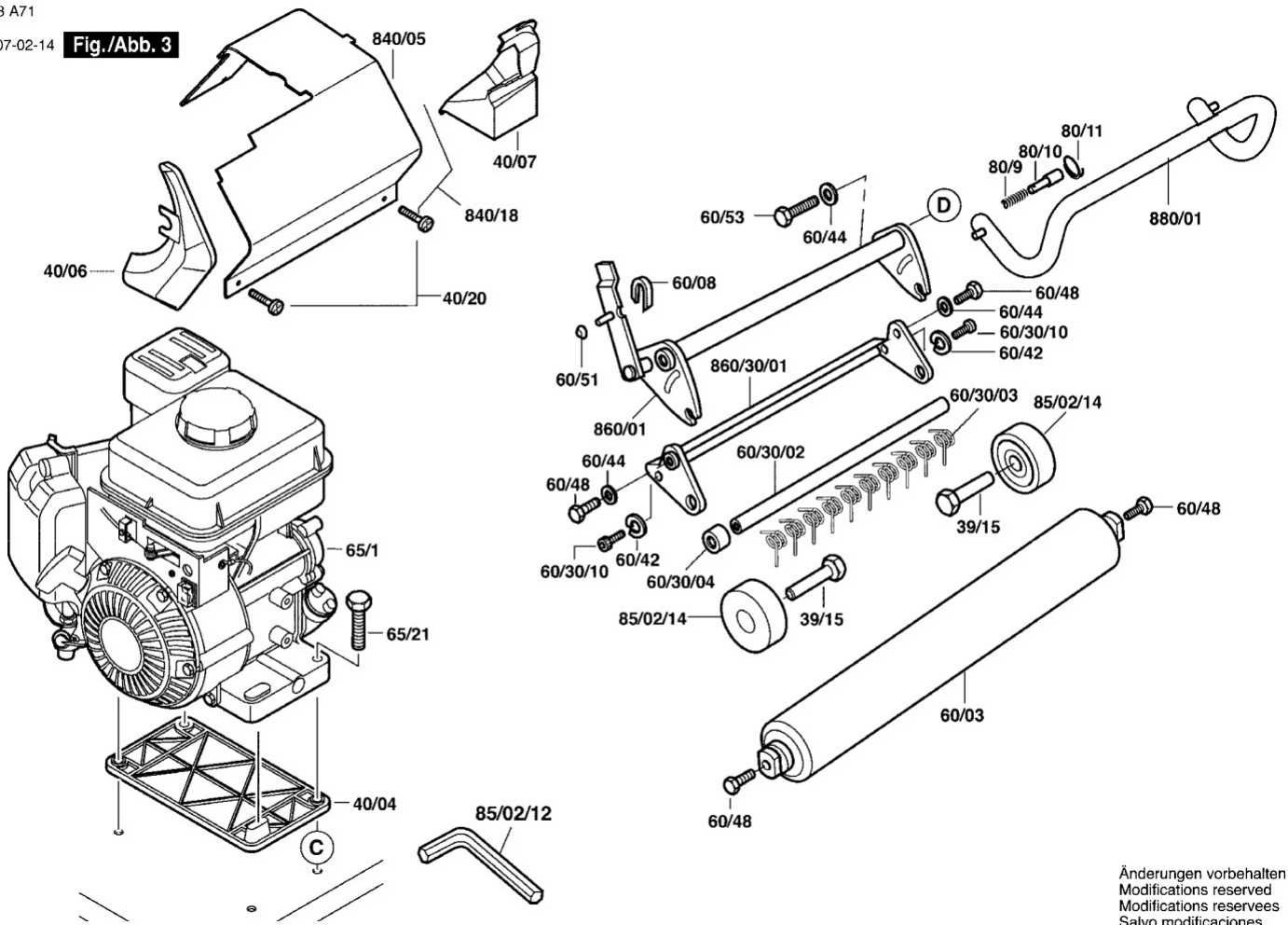

Änderungen vorbehalten  
 Modifications reserved  
 Modifications reserves  
 Salvo modificaciones

3616C08A713 . 24/07/2013



Steve Hancke  
 Allett  
 Allett Mowers  
 Turfmech Machinery Ltd  
 Stafford  
 ST18 0PJ  
 United Kingdom

Date: 24/07/2013  
 Tel: 01889 272093  
 Fax:  
 Email: steve.hancke@allett.co.uk

Service Bill of Materials: 3616C08A713

Ref	Part #	Qty	Description	Price	RP	RD
39/15	F016A75784	2	Axle			
40/04	F016A75702	1	Platform			
40/06	F016A75707	1	Sealing cap			
40/07	F016A75708	1	Sealing cap			
40/20	F016A57756	5	Cross Recessed-Head Screw M5 M5			
60/03	F016A75794	1	Roller			
60/08	F016A57675	1	Bushing			
60/30/02	F016L64561	1	Spindle			
60/30/03	F016A57887	41	Spring			
60/30/04	F016A57930	1	Spacer			
60/30/10	F016L18120	2	Hex Screw M 6x12 M 6x12			
60/48	F016T48048	4	Hex Screw M 8 M 8			
60/53	F016W25213	1	Hex Screw WAS 170 WAS 170			
65/21	F016A58093	2	Trunnion M8 M8			
80/9	F016A58364	1	Location Pin			
80/10	F016A58365	1	Spring			
80/11	F016A58366	1	Retaining snap ring			
840/05	F016S50077	1	Protection cover 17"			
860/01	F016103696	1	Roller Carrier			
860/30/01	F016103699	1	Rake			
880/01	F016103780	1	Support Tube			

Steve Hancke, Steve Hancke, Allett, Allett Mowers, Turfmech Machinery Ltd, Stafford, ST18 0PJ, United Kingdom, .

3 616 C08 A71

Stand } 07-02-12 **Fig./Abb. 4**  
 Issue }

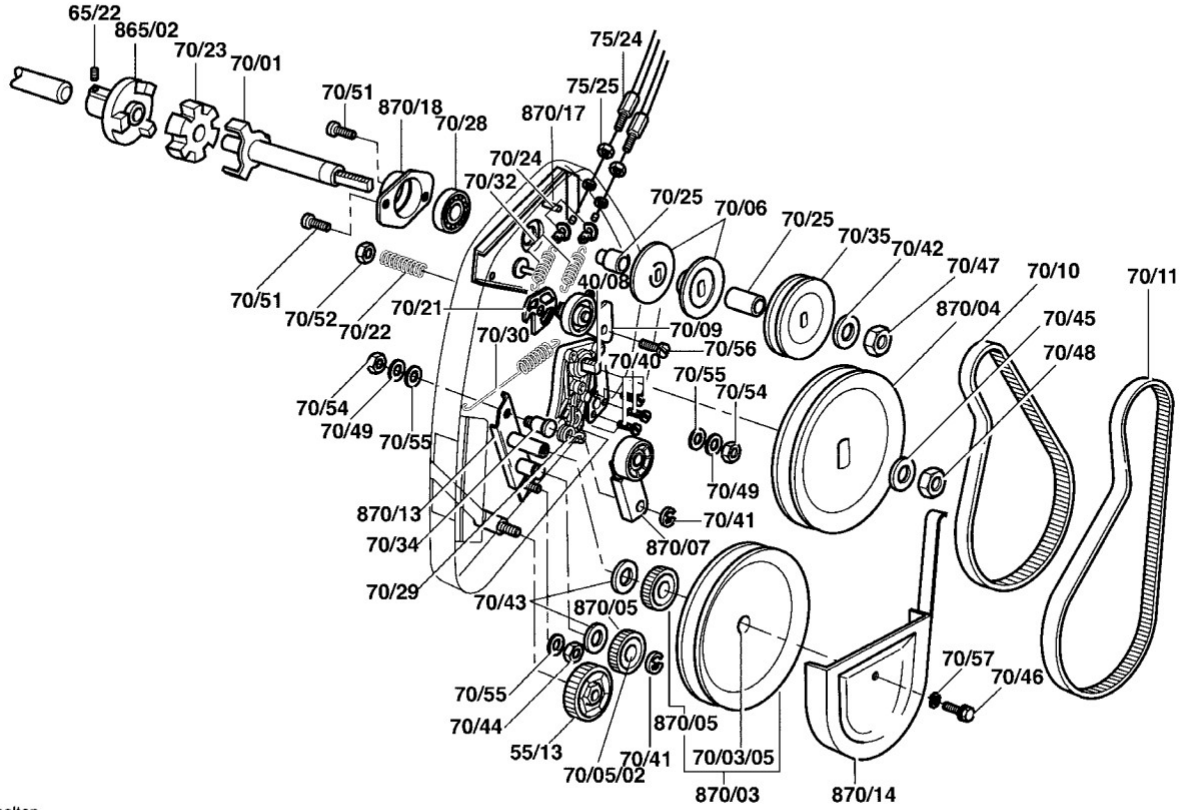

Änderungen vorbehalten  
 Modifications reserved  
 Modifications reserves  
 Salvo modificaciones

3616C08A714 . 24/07/2013



Steve Hancke  
 Allett  
 Allett Mowers  
 Turfmech Machinery Ltd  
 Stafford  
 ST18 0PJ  
 United Kingdom

Date: 24/07/2013  
 Tel: 01889 272093  
 Fax:  
 Email: steve.hancke@allett.co.uk

## Service Bill of Materials: 3616C08A714

Ref	Part #	Qty	Description	Price	RP	RD
55/13	F016A57590	1	Cylinder Toothed Gear			
65/22	F016L20896	2	Screw			
70/01	F016A75666	1	Drive Shaft			
70/03/05	F016A57764	1	Bushing			
70/05/02	F016A57761	1	Bushing			
70/06	F016A58726	2	Pulley 46 MM			
70/10	F016A58728	1	46 MM Roller Drive Belt			
70/11	F016A57941	1	Cylinder Drive Belt			
70/21	F016A58315	1	Spacer			
70/22	F016A58316	1	Spring			
70/23	F016L09518	1	Coupling			
70/24	F016L66172	2	Support			
70/25	F016A57780	3	Spacer			
70/28	F016A57838	1	Ball Bearing			
70/29	F016A58531	1	Governor Spring			
70/30	F016A58530	1	Governor Spring			
70/32	F016L08487	2	Spring			
70/34	F016A58422	1	Journal			
70/35	F016L09227	1	Pulley			
70/41	F016A57759	2	Spring retaining ring			
70/42	F016L35411	1	Plain Washer 8,5 MM 8,5 MM			
70/43	F016A58725	2	Plain Washer M 16 M 16			
70/44	F016L11218	1	Self-locking nut M8 M8			
70/45	F016L17849	1	Plain Washer			
70/46	F016L18120	1	Hex Screw M 6x12 M 6x12			
70/48	F016L23210	1	Nut M12 M12			
70/49	F016L35307	2	Spring Washer 5/16 SW SE 5/16 SW SE			
70/51	F016L35387	2	Self-Cutting Screw M6 M6			
70/52	F016L35388	1	Self-locking nut M6 M6			
70/54	F016L35457	2	Nut M8 M8			
70/55	F016T42988	2	Washer			
70/56	F016T48017	1	Trunnion			
70/57	F016L35389	1	Locking Washer			
870/03	F016102377	1	Pulley & Gear			
870/04	F016103221	1	Roller Pulley			
870/05	F016102379	1	Toothed Gear			
870/07	F016102282	1	Roller			
870/13	F016102977	1	Gear Support S/A S/A			
870/14	F016102818	1	Guide Piece			
870/17	F016103154	1	Release Disc			
870/18	F016103153	1	Bearing Holder			



Steve Hancke, Steve Hancke, Allett, Allett Mowers, Turfmech Machinery Ltd, Stafford, ST18 0PJ, United Kingdom, .

3 616 C08 A71

Stand } 07-02-12 **Fig./Abb. 5**  
 Issue }

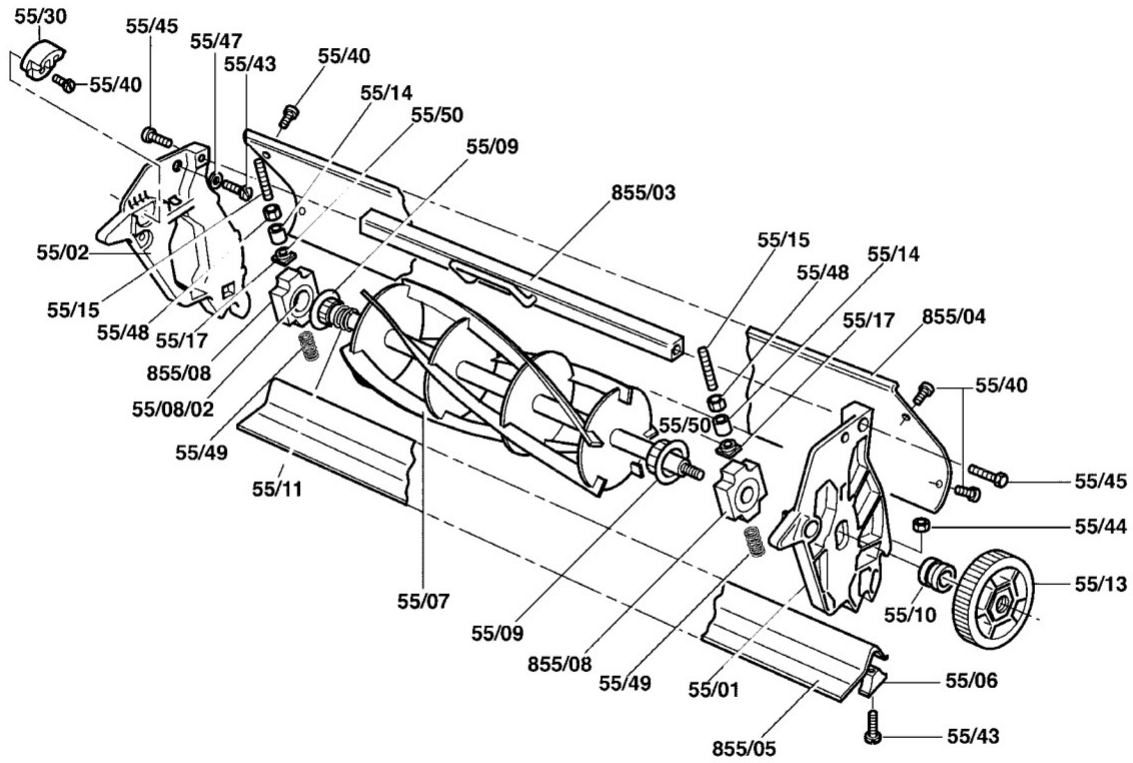

Änderungen vorbehalten  
 Modifications reserved  
 Modifications reserves  
 Salvo modificaciones

3616C08A715 . 24/07/2013



Steve Hancke  
 Allett  
 Allett Mowers  
 Turfmech Machinery Ltd  
 Stafford  
 ST18 0PJ  
 United Kingdom

Date: 24/07/2013  
 Tel: 01889 272093  
 Fax:  
 Email: steve.hancke@allett.co.uk

Service Bill of Materials: 3616C08A715

Ref	Part #	Qty	Description	Price	RP	RD
55/01	F016A75001	1	Side Plate L/H L/H			
55/02	F016A75002	1	Side Plate R/H R/H			
55/06	F016A75065	2	Spacing Block			
55/07	F016A58820	1	Spindle			
55/08/02	F016A58741	2	Bearing			
55/09	F016A58854	2	Shield			
55/10	F016A58855	1	Sleeve			
55/11	F016A58856	1	Clamping Spring			
55/14	F016A57669	2	Adjusting Part			
55/15	F016A57713	2	Adjusting Screw			
55/17	F016T41057	2	Square Shaft			
55/30	F016A58811	2	Buffer			
55/40	F016A57756	6	Cross Recessed-Head Screw M5 M5			
55/43	F016A58229	2	Screw M6 M6			
55/44	F016L35388	2	Self-locking nut M6 M6			
55/45	F016T49288	2	Screw M6x25 Hex M6x25 Hex			
55/48	F016L35457	2	Nut M8 M8			
55/49	F016T47205	2	Spring			
55/50	F016T49443	2	Washer			
855/03	F016A75052	1	Cartridge Handle 17"			
855/04	F016103771	1	Deflector Plate			
855/05	F016101517	1	Lower Blade			
855/08	F016102805	2	Bearing Housing Assembly			

3 616 C08 A71

Stand } 07-02-12 **Fig./Abb. 6**  
Issue }

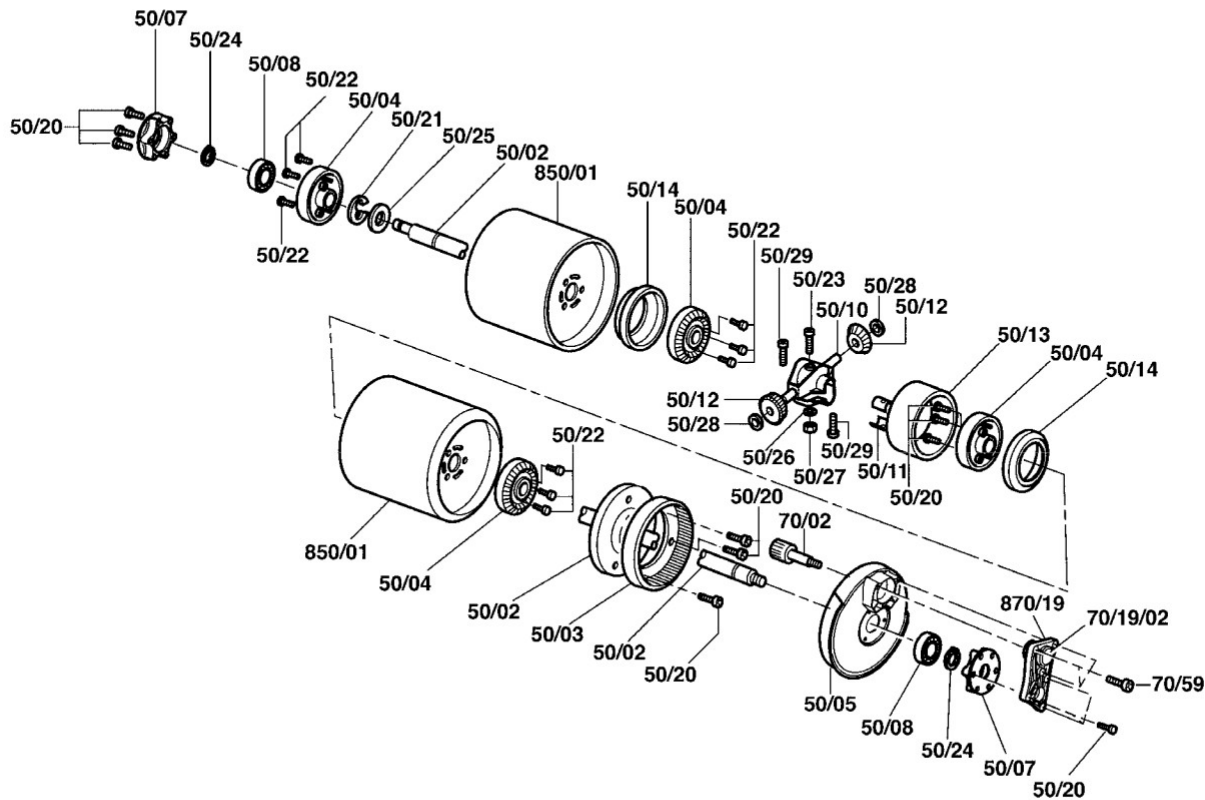

Änderungen vorbehalten  
Modifications reserved  
Modifications reserves  
Salvo modificaciones



Steve Hancke  
 Allett  
 Allett Mowers  
 Turfmech Machinery Ltd  
 Stafford  
 ST18 0PJ  
 United Kingdom

Date: 24/07/2013  
 Tel: 01889 272093  
 Fax:  
 Email: steve.hancke@allett.co.uk

Service Bill of Materials: 3616C08A716

Ref	Part #	Qty	Description	Price	RP	RD
50/02	F016A58437	1	Spindle Assembly			
50/03	F016A57635	1	Ring			
50/04	F016A57674	4	Toothed Gear			
50/05	F016A75403	1	Protection cover			
50/07	F016102093	2	Bearing Holder			
50/08	F016A57838	2	Ball Bearing			
50/10	F016L66596	2	Clamping Piece			
50/11	F016A58483	2	Clamp			
50/12	F016A57499	2	Toothed Gear			
50/13	F016A57832	1	Plate			
50/14	F016A57823	2	Plastic Collar			
50/20	F016A57756	9	Cross Recessed-Head Screw M5 M5			
50/21	F016A57758	1	Outer Ring			
50/22	F016A58178	9	Rivet Pin			
50/23	F016A58385	1	Screw			
50/24	F016A58441	2	Retaining clip			
50/25	F016A58577	7	Plain Washer M 20 M 20			
50/26	F016L35316	1	Plain Washer 8,5 MM 8,5 MM			
50/27	F016L35388	1	Self-locking nut M6 M6			
50/28	F016T49100	2	Set ring 12 MM T40 12 MM T40			
50/29	F016T46295	2	Screw			
70/02	F016102295	1	Shaft			
70/19/02	F016A57764	2	Bushing			
70/59	F016T49429	3	Self-Cutting Screw 4x19 MM 4x19 MM			
850/01	F016103776	2	Roller			
870/19	F016103210	1	Holder			